



*Provide the best  
protection solutions*

# HFC-227ea

Engineered  
Fire Extinguishing  
System



# SP Series

## HFC-227ea Fire Extinguishing System

The Mosafe Fire Systems SP Series Clean Agent Fire Extinguishing System utilizes HFC-227ea as the extinguishing medium. HFC-227ea is a colorless, non-toxic gas perfectly suited to protect high value assets in areas that may be normally occupied, in locations where clean-up of other agents is problematic, when storage space for a fire suppression agent is restricted, or when an electrically non-conductive agent is required. Each system consists of the following components and their associated accessories:

- 1 HFC-227ea Storage Components** - Storage components consist of the cylinder assembly (s), which contains the HFC-227ea chemical agent, and the cylinder bracket(s), which holds the cylinder assembly securely in place.
- 2 HFC-227ea Distribution Components** - Distribution components consist of the discharge nozzles used to introduce the HFC-227ea agent into a protected hazard along with the associated piping system used to connect the nozzles to the cylinder assembly.
- 3 Trim Components** - Trim components complete the installation of the HFC-227ea system and consist of connection fittings, pressure gauge, low-pressure supervisory switch, electric valve actuator, and manual valve actuator.
- 4 Slave Arrangement Components** - Slave arrangement components consist of the pneumatic valve actuator(s), actuation check valve, bleed valve, pilot hose, and fittings required for a multiple cylinder (slave) arrangement.
- 5 Supplemental Components** - Supplemental components include the discharge pressure switch and manifold check valve. They supplement the core equipment or complete a specific multi-cylinder configuration.
- 6 Control Panel** - This device monitors the condition of the electric actuator, detectors, warning devices, cylinder pressure, and any manual release and abort stations. All electric or electronic devices must connect to the control panel in order to function.

Typical Clean Agent System Layout

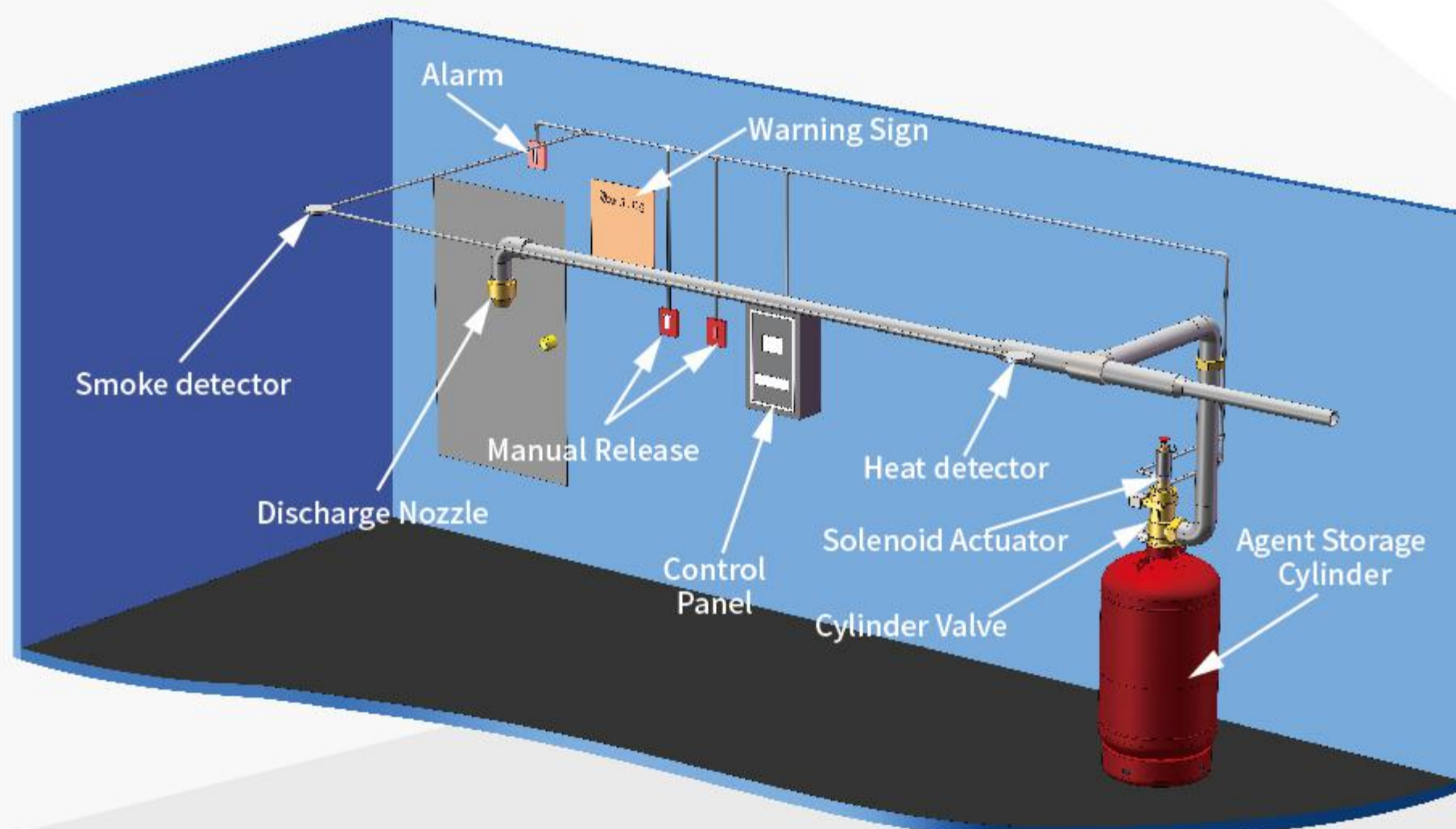

## EQUIPMENT DESCRIPTION

The HFC-227ea agent is stored as a liquid in cylinder assemblies designed specifically for the application and charged to a fill density of between 480 kg/m<sup>3</sup> and 1121 kg/m<sup>3</sup>. To ensure optimal performance, each cylinder is superpressurized with dry nitrogen to 25 or 42 bar at 21°C. An identification label is affixed to the cylinder body indicating the fill quantity of HFC-227ea, charging pressure, date of fill, and fill station. The SP Series supports three cylinder capacities.

HFC-227ea fire extinguishing systems are designed to be discharged within 10 seconds into a room, area, or enclosure with the structural integrity to retain the agent. The HFC-227ea uniformly mixes throughout the protected area, achieving a minimum concentration level in accordance with NFPA 2001 and/or agency listings.

Cylinder with Valve Assembly Part No.	Nominal Working Pressure (bar)	Nominal Cylinder Volume (L)	Fill Capacity(kg)		Outlet Size (mm)	Empty Weight (kg)
			Min.	Max.		
811.101.0156	25	40	19.2	44.8	49	52
811.101.0158	42					
811.101.0166	25	50	24.0	56.0	49	57
811.101.0168	42					
811.101.0176	25	60	28.8	67.2	49	68
811.101.0178	42					
811.101.0186	25	70	33.6	78.4	49	67
811.101.0188	42					
811.101.0196	25	80	38.4	89.6	49	72
811.101.0198	42					
811.101.0206	25	90	43.2	100.8	49	84
811.101.0208	42					
811.101.0216	25	100	48.0	112.0	49	89
811.101.0218	42					
811.101.0226	25	120	57.6	134.4	49	99
811.101.0228	42					
811.101.0236	25	150	72.0	168.0	49	114
811.101.0238	42					
811.101.0246	25	180	86.4	201.6	49	146
811.101.0248	42					
811.101.0155	25	40	19.2	44.8	33	50
811.101.0157	42					
811.101.0165	25	50	24.0	56.0	33	55
811.101.0167	42					
811.101.0175	25	60	28.8	67.2	33	60
811.101.0177	42					

The cylinder assembly is composed of a cylinder, dip tube, cylinder valve, safety release.

**Cylinder Valve:** The automatic release of HFC-227ea is controlled by a forged brass, differential pressure operated cylinder valve connected to the neck of the cylinder. The valve assembly is shipped with an anti-recoil safety device installed in the discharge outlet and chained to the cylinder valve.

**Dip Tube:** A threaded, rigid dip tube extends from the cylinder neck down to its bottom.

**Cylinder:** The light walled, welded seam cylinder is manufactured according to the requirements of TPED. Internal neck threads allow connection of the cylinder valve. The cylinder is designed for mounting in a vertical position only.

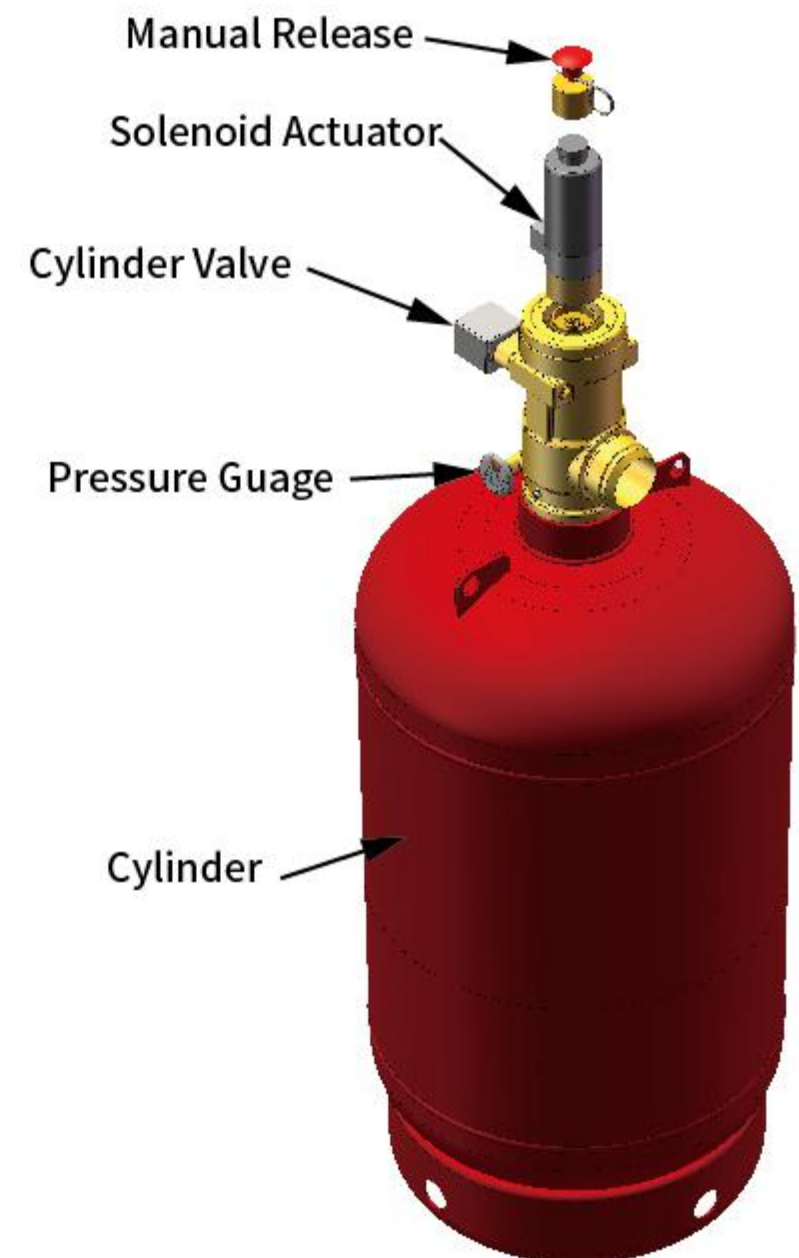

The cylinder valve has five connection points:

**Valve Actuation Connection:** A threaded connection located on top of the cylinder valve serves as the attachment point for the electric (primary) or pneumatic (slave) valve actuator.

**Pressure Gauge Connection:** A female connection serves as the attachment point for the pressure gauge. It is fitted with an internal check valve to allow removal of the gauge while the cylinder is pressurized.

**Discharge Outlet:** A 1.25 in (33mm) or 2 in (49mm) male thread connection serves as the attachment point for discharge piping.

**Pilot Actuation Port:** A 1/4 in (8 mm) FNPT connection (shipped with a removable plug) provides a means of applying actuation pressure to the slave cylinder(s). This can also be used for attachment of the discharge pressure switch in single cylinder arrangements. The port is pressurized only during the 10 second discharge period.

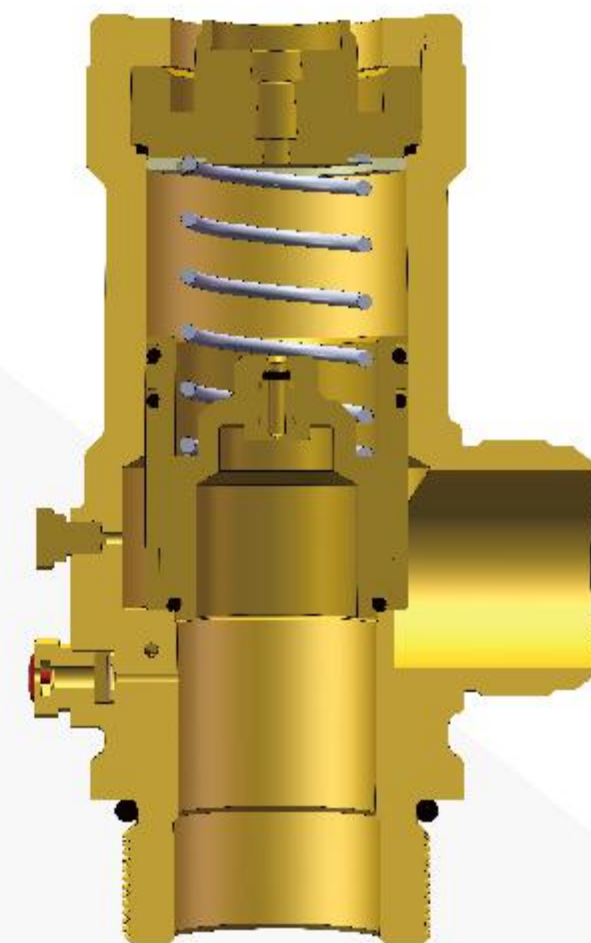

# CYLINDER MOUNTING

## Wall Mount Cylinder Bracket Assembly

Cylinder stability is ensured by the cylinder bracket assembly, consisting of one strap and rail with accompanying bolts, nuts, and washers. The rail is slotted for ease of mounting with fasteners provided by the installer.

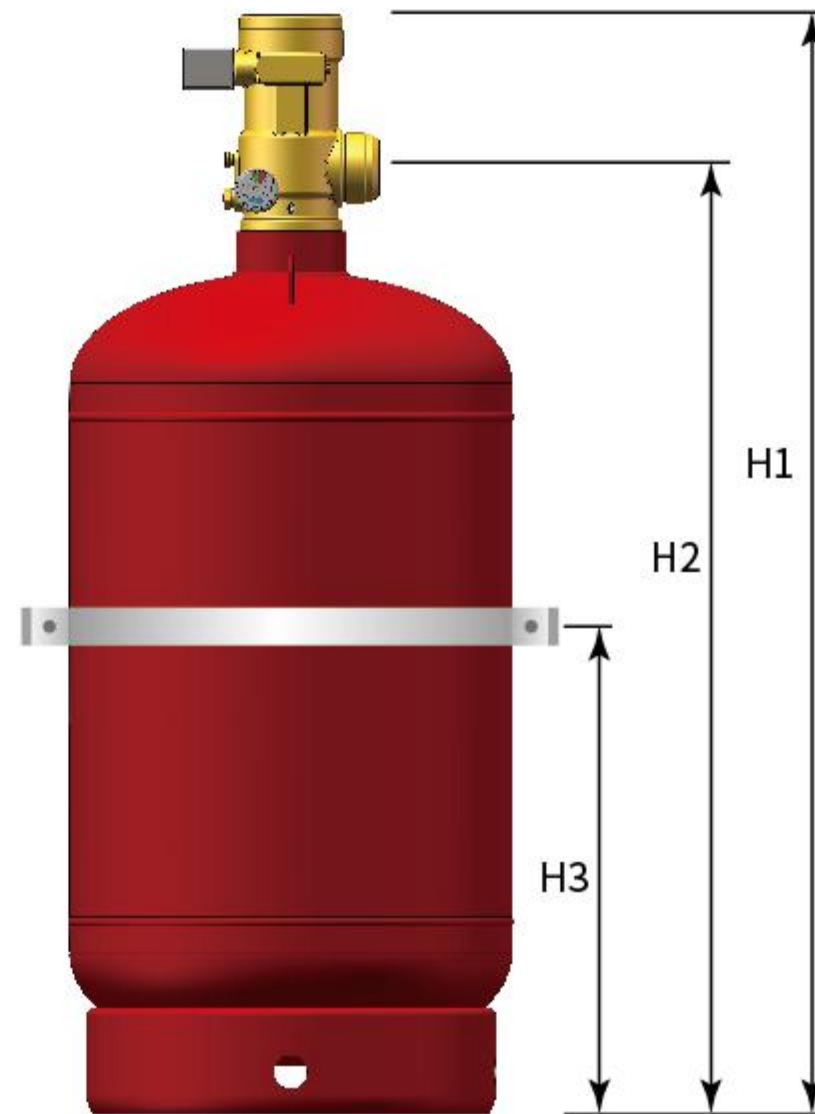

Cylinder Assembly Dimension						
Part No.	Nominal Working Pressure (bar)	Nominal Cylinder Volume (L)	H1 (mm)	H2 (mm)	H3 (mm)	D (mm)
811.101.0156	25	40	841	695	290	ø324
811.101.0158	42					
811.101.0166	25	50	969	823	400	ø324
811.101.0168	42					
811.101.0176	25	60	1102	956	500	ø324
811.101.0178	42					
811.101.0186	25	70	1230	1085	600	ø324
811.101.0188	42					
811.101.0196	25	80	1362	1216	700	ø324
811.101.0198	42					
811.101.0206	25	90	1084	938	500	ø406
811.101.0208	42					
811.101.0216	25	100	1165	1020	550	ø406
811.101.0218	42					
811.101.0226	25	120	1329	1183	700	ø406
811.101.0228	42					
811.101.0236	25	150	1575	1429	800	ø406
811.101.0238	42					
811.101.0246	25	180	1475	1329	800	ø462
811.101.0248	42					
811.101.0155	25	40	777	674	290	ø324
811.101.0157	42					
811.101.0165	25	50	905	802	400	ø324
811.101.0167	42					
811.101.0175	25	60	1038	935	500	ø324
811.101.0177	42					

## ▶ TRIM COMPONENTS

Trim components are required to operate the HFC-227ea cylinder(s).

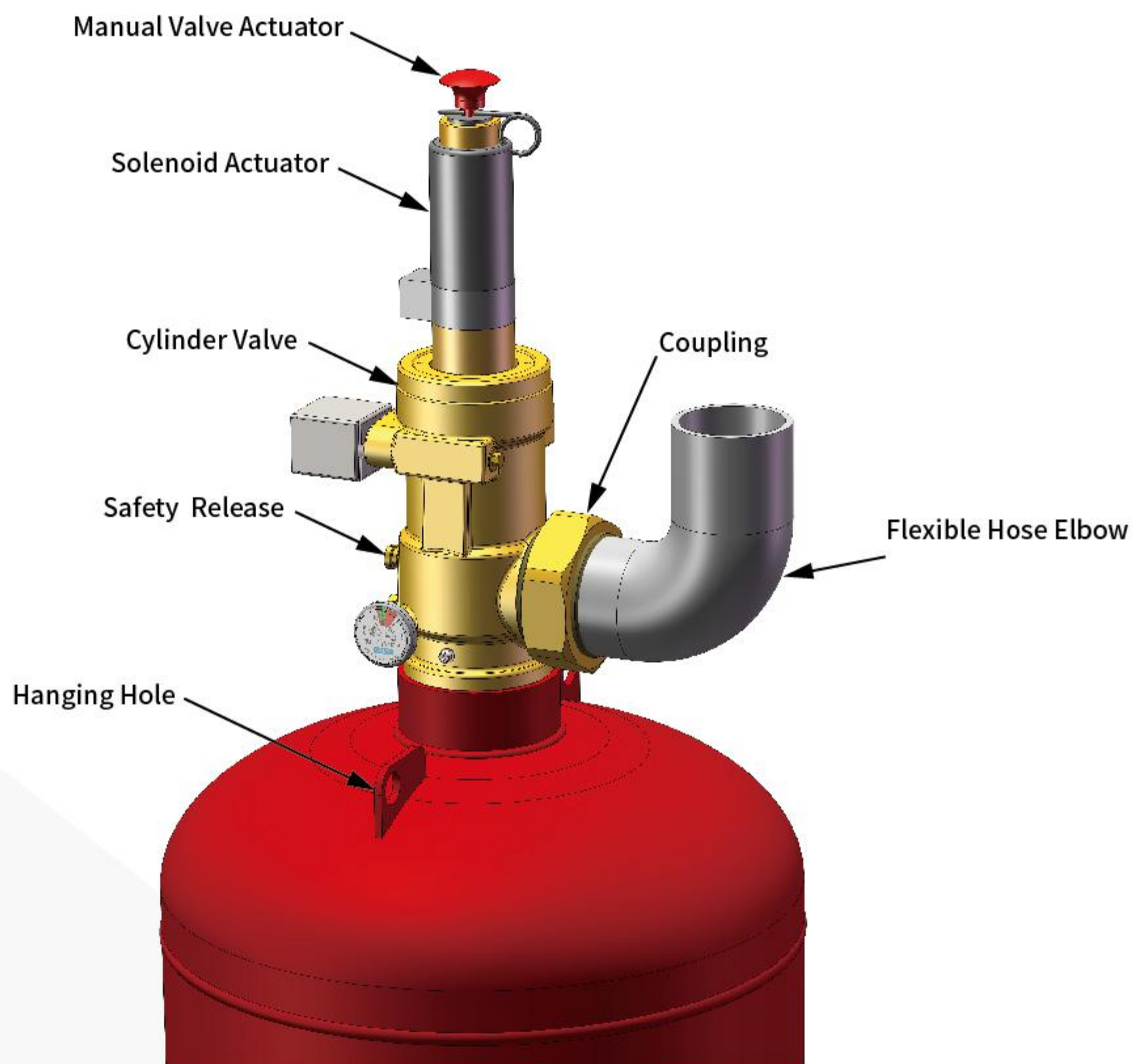

### Discharge Connection Fittings

A 1.25 in (33 mm) or 2 in (49mm) female thread elbow connects to the male thread cylinder outlet adapter utilizing the coupling factory installed to retain the anti-recoil safety device.

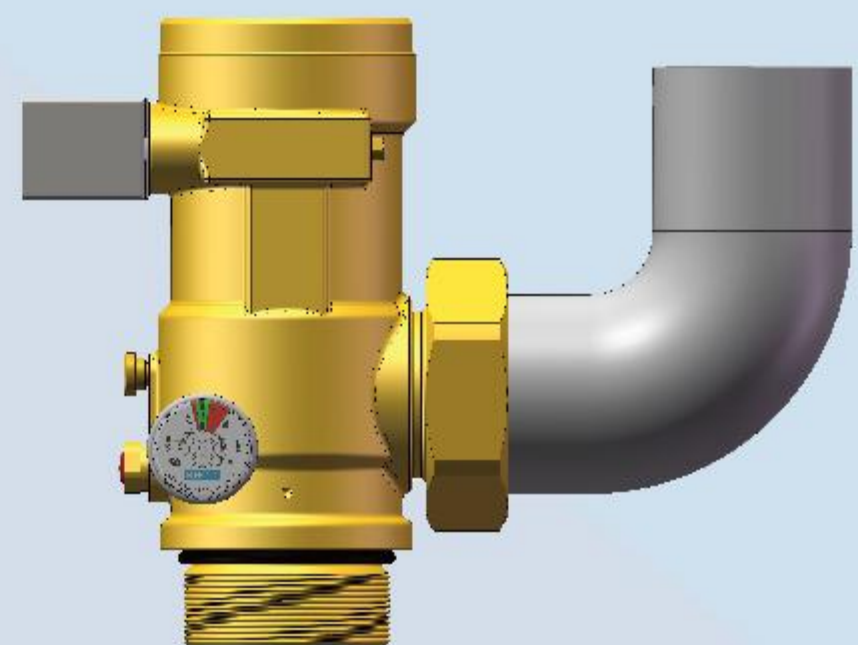

### Pressure Gauge Assembly

NFPA 2001 mandates a pressure gauge for each cylinder as a method of visually monitoring the internal pressure condition of the cylinder assembly.



## Solenoid Actuator w/ Supervisory Limit Switch

The Solenoid actuator attaches to the master cylinder at the valve actuation connection and is utilized to automatically open the cylinder valve upon receipt of a signal from the control panel or other source.

The Solenoid actuator is construction with a stainless steel actuation pin that depresses the valve core when energized. The switch contacts are normally closed when the actuator is not installed onto the cylinder valve and open when the actuator is fully installed onto the valve actuation connection at the top of the cylinder valve.

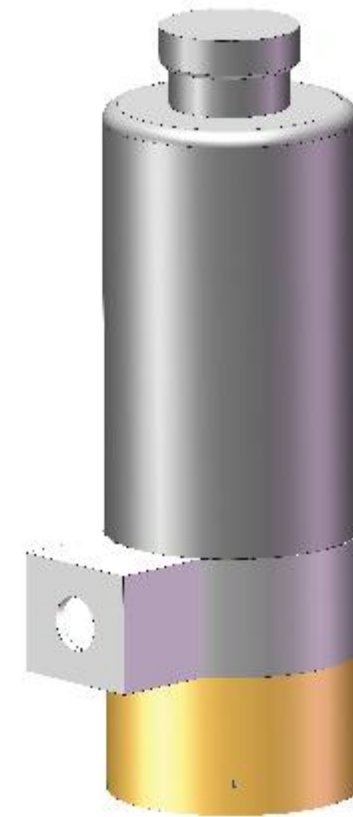

## Manual Valve Actuator

An optional manual valve actuator attaches to the top of the solenoid actuator and provides a means to manually open the cylinder valve.

All other connected cylinders will be opened pneumatically.

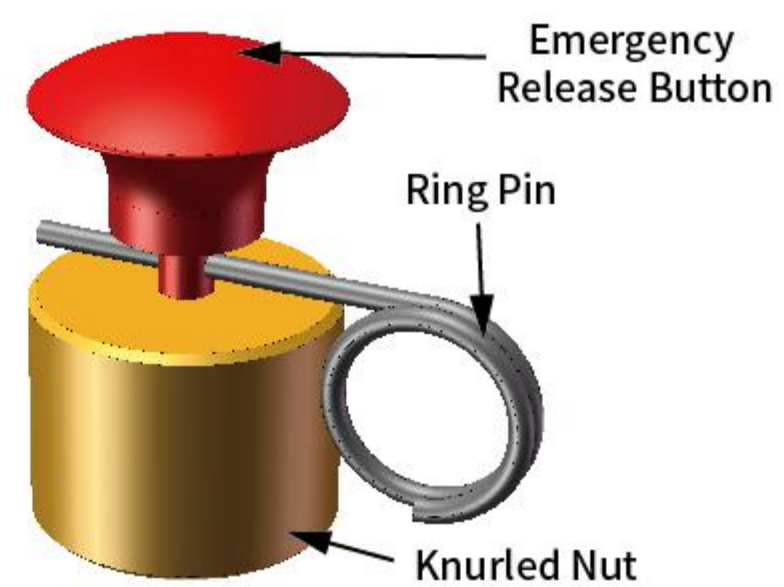

## SLAVE ARRANGEMENT COMPONENTS

Up to 7 cylinders (1 primary and 6 slave) may be installed in a single arrangement. A typical arrangement is shown below.

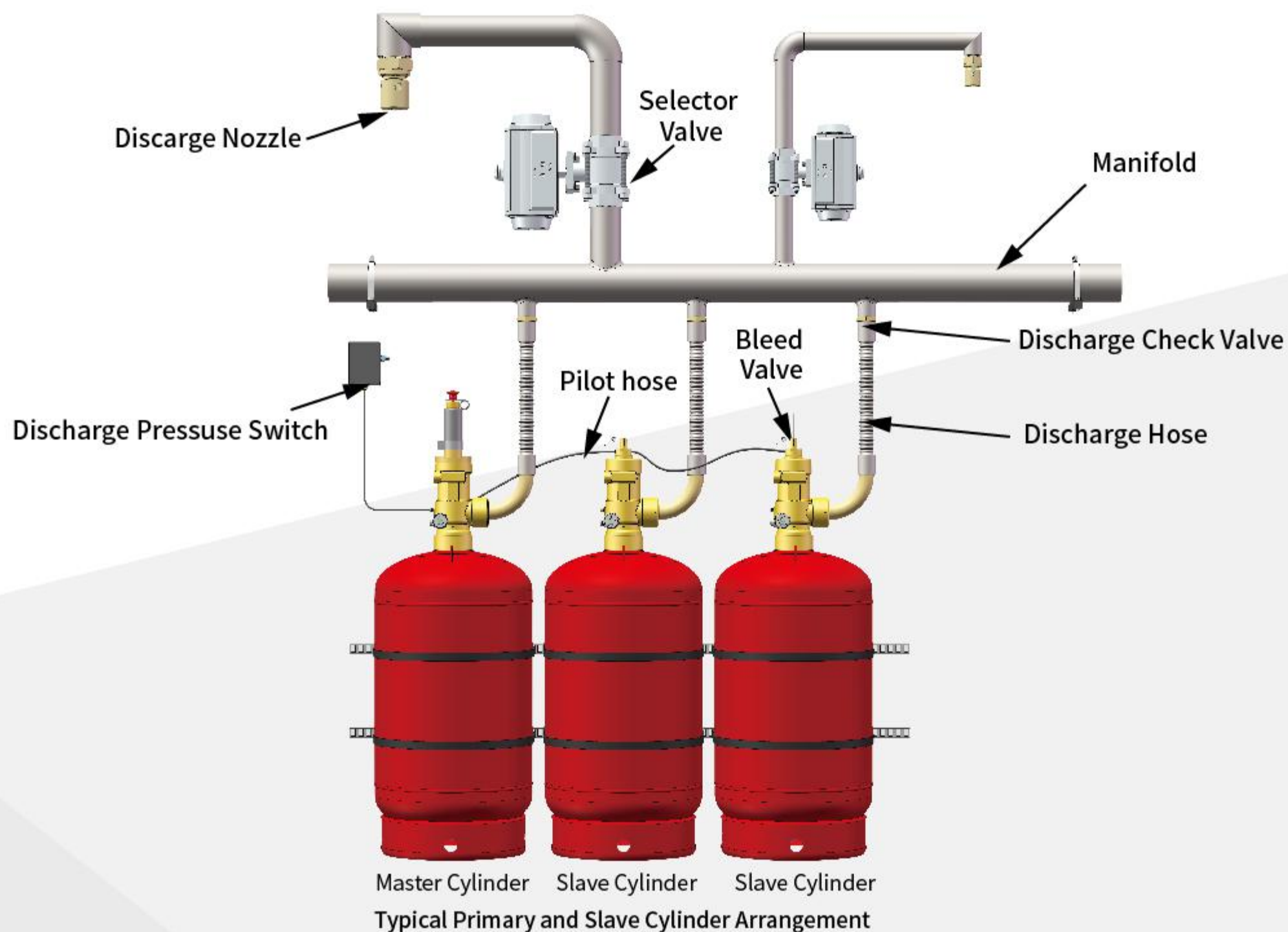

## Pneumatic Valve Actuator

On multiple cylinder systems the electric valve actuator will open the primary cylinder and then, in a rapidly occurring sequence, the pneumatic valve actuator(s) will open all other cylinders using pressure from the primary cylinder.

A pneumatic valve actuator attaches to the valve actuation connection of each slave cylinder. It receives pressure from the pilot actuation port of the primary cylinder through the pilot actuation check valve. It is brass with a brass piston and pin.

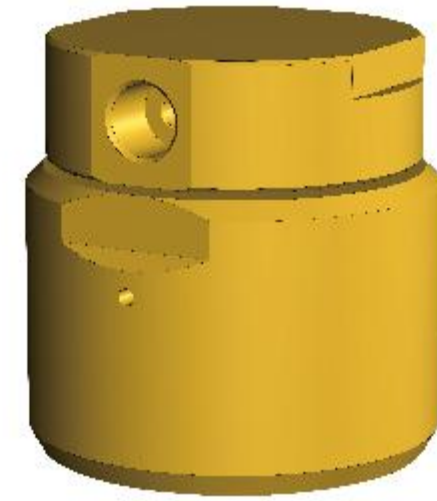

## Bleed Valve

The bleed valve is a safety device with G1/8 male threads that is to be installed in the pilot actuation line end. It is used to bleed off pressure that may accumulate in the pilot actuation hose or piping minimizing the chance of inadvertent pressurization of the pneumatic actuators or discharge pressure switch.

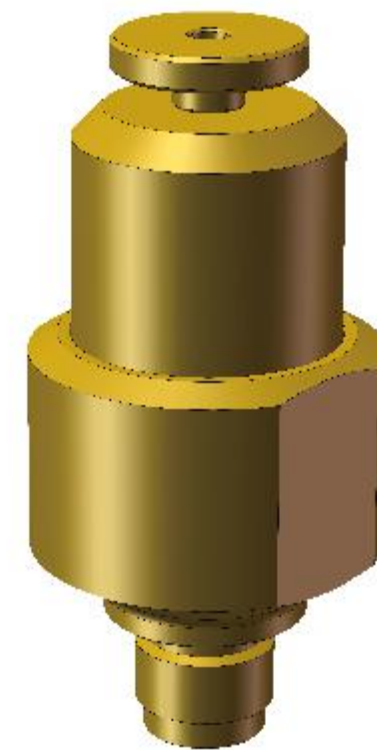

## Pilot Hose

Pilot Hoses are 6 mm rubber hoses of varying lengths with 1/4 in (8 mm) 37 ° female JIC flare fittings. They are utilized to interconnect cylinders when a slave arrangement is required. A 1/4 in (8 mm) 37 ° male JIC flare x male JIC flare adapter is available to connect lengths of Pilot Hose together.

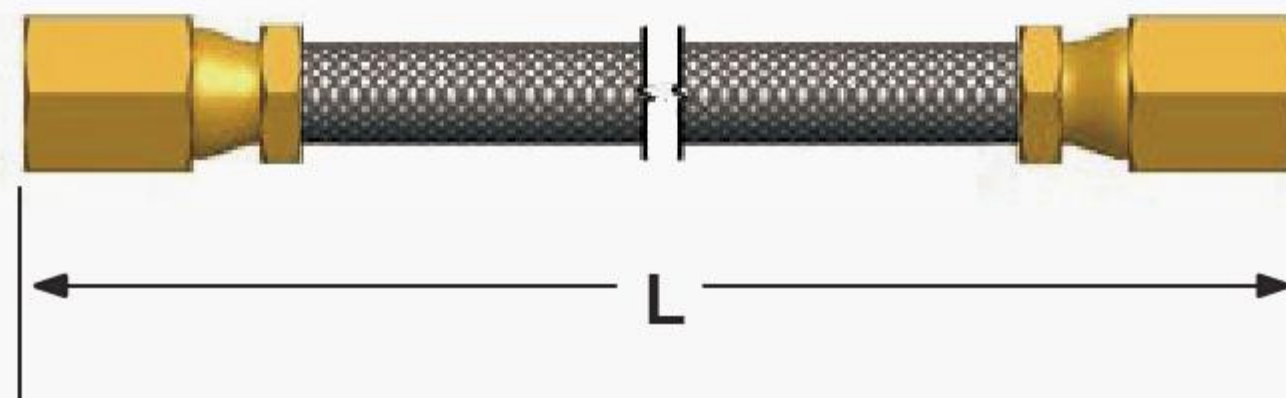

Part No.	Nominal Diameter (mm)	Hose Length (mm)	Install Thread
811.102.003	ø6	400	M12 x 1.5
811.102.004	ø6	500	M12 x 1.5
811.102.005	ø6	700	M12 x 1.5



## SUPPLEMENTAL COMPONENTS

Supplemental components complete various system arrangements.

### Discharge Pressure Switch

The discharge pressure switch is used in the system to provide positive indication of agent discharge and to initiate the shut down of equipment that may deplete agent concentration. The pressure switch is a single pole, double throw (SPDT) switch with contacts rated 10 Amps resistive at 30 VDC.

### Manifold Check Valve

In a multiple cylinder arrangement where the slave and master cylinders share a common manifold or in a main / reserve arrangement, a 1.25 in or 2 in thread manifold check valve must be placed between the discharge outlet of each cylinder and the discharge manifold to prevent back flow from the manifold should the system be inadvertently discharged when one or more cylinders are disconnected for maintenance.

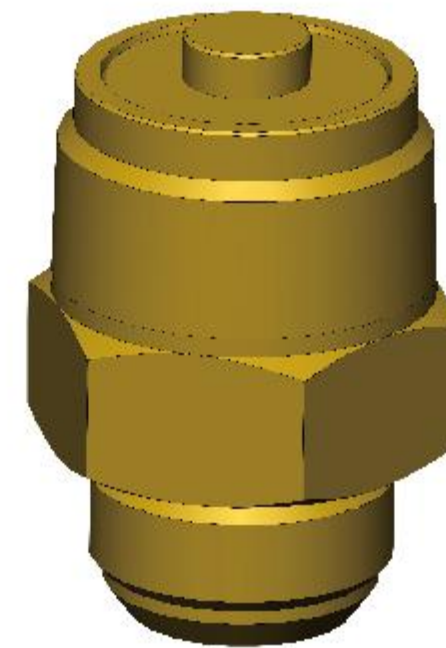

## DISCHARGE NOZZLES

Discharge nozzles are used to uniformly distribute the HFC-227ea agent. They are performance tested to ensure that the agent is discharged within 10 seconds and properly dispersed throughout the protected area. Maximum nozzle height for a protected space is 5500 mm per tier of nozzles. Additional tiers are required for heights greater than 5500mm.

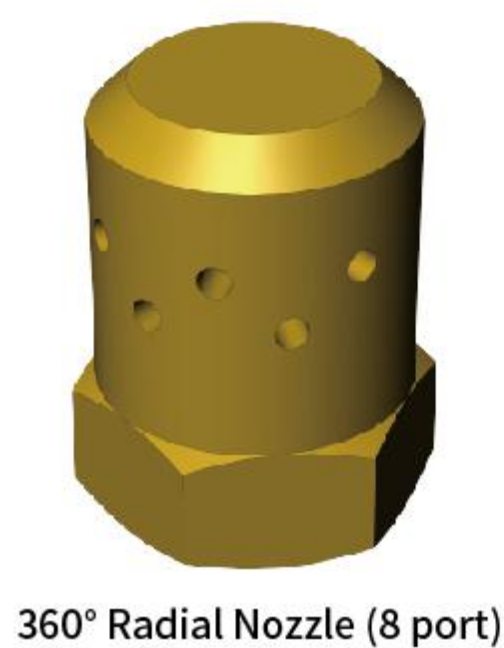

360° Radial Nozzle (8 port)

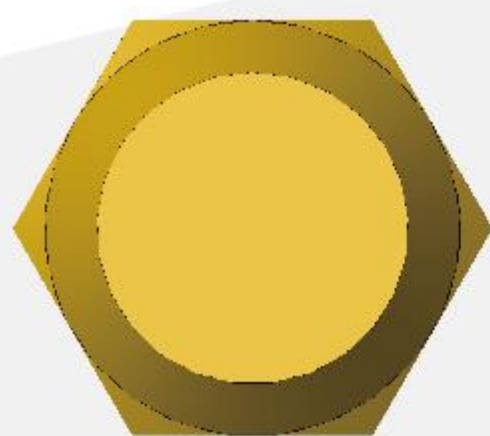

Discharge Nozzle  
Top View

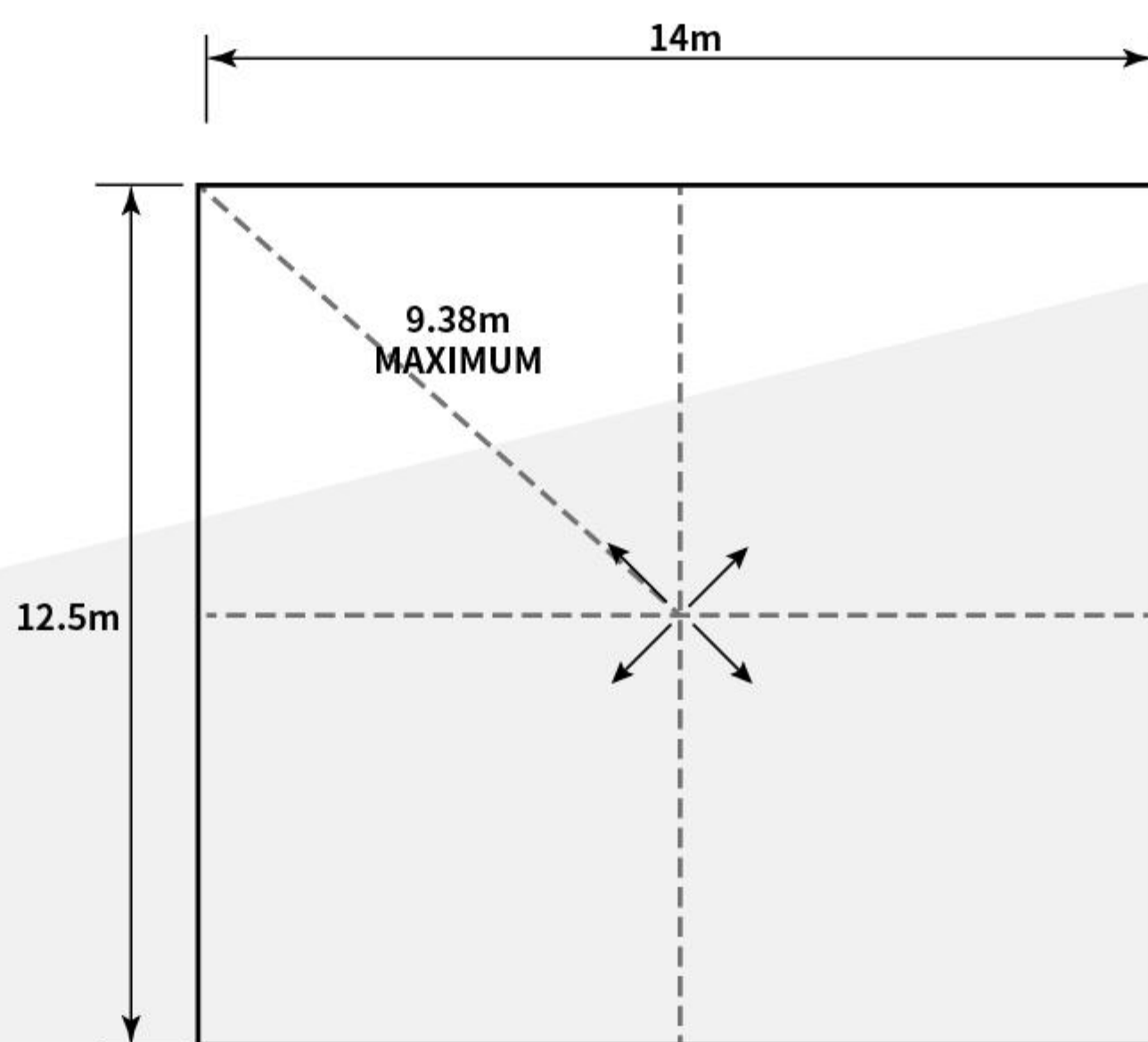

360° Radial Nozzle (8 Port) Arrangement

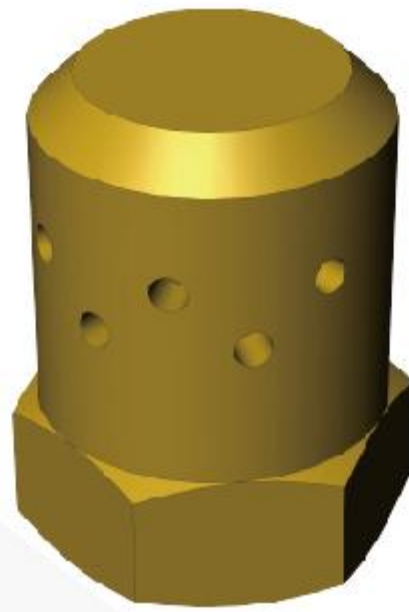

180° Sidewall Nozzle (8 Port)

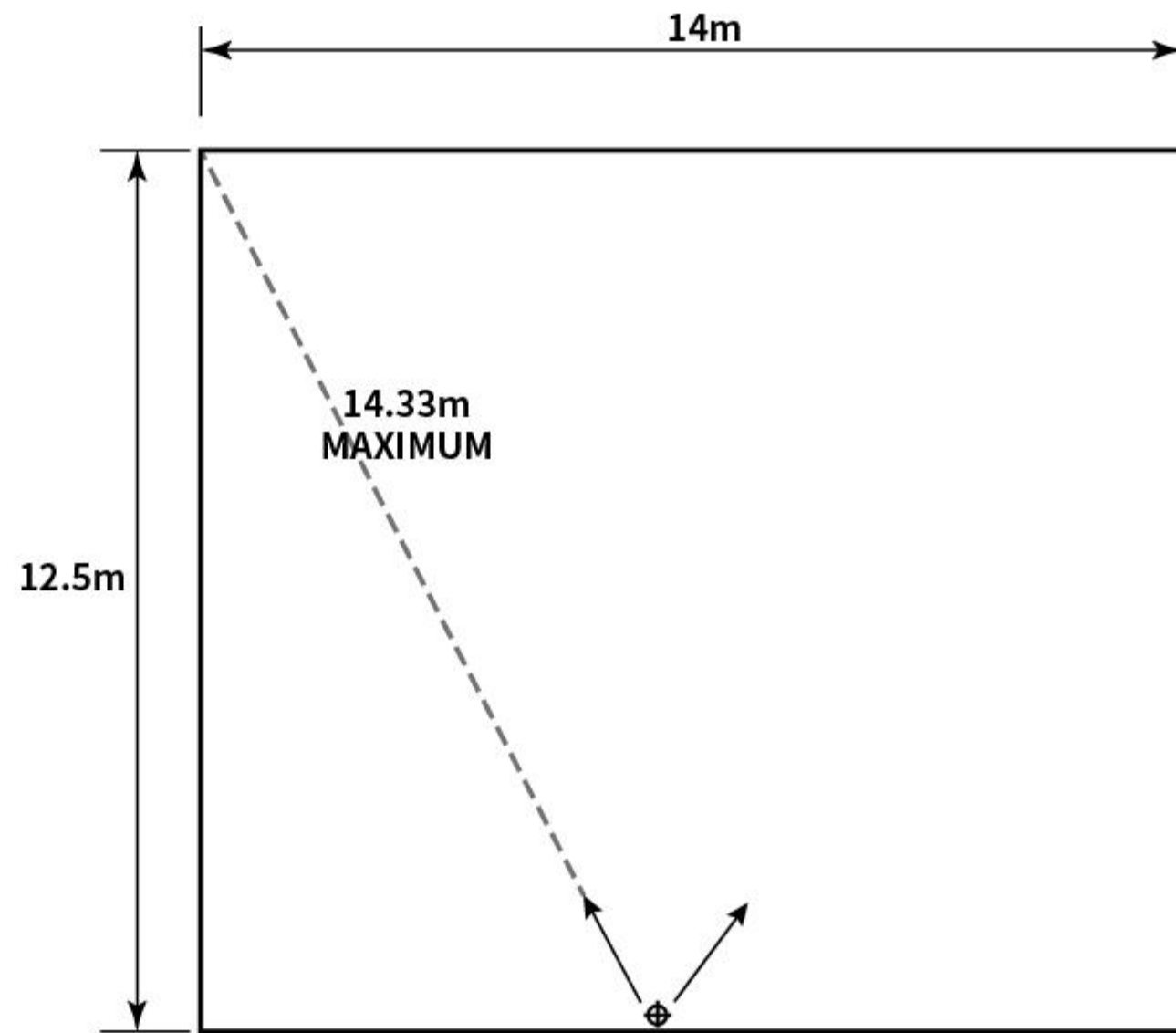

180° Sidewall Nozzle (8 Port) Arrangement

## ▶ HFC-227ea CHEMICAL PROPERTIES

HFC-227ea is formed from the elements carbon, fluorine and hydrogen (CF<sub>3</sub>CHF<sub>2</sub>CF<sub>3</sub> - heptafluoropropane). The primary extinguishing mechanism of HFC-227ea is heat absorption, with a secondary chemical contribution from the thermal decomposition of HFC-227ea in the flame.

HFC-227ea leaves no residue and is safe for use in occupied spaces.

Most common metals, such as aluminum, brass, steel, cast iron, lead, stainless steel, and copper, as well as rubber, plastic, and electronic components, are unaffected when exposed to HFC-227ea.

## ▶ SAFETY CONSIDERATIONS

Although the EPA Significant New Alternative Program (SNAP) lists HFC-227ea as acceptable for occupied spaces, NFPA Standard 2001 and SNAP list the following guidelines for human exposure:

The discharge of HFC-227ea into a hazard may reduce visibility for a brief period. HFC-227ea may cause frostbite if liquid discharge or escaping vapor contacts the skin.

When HFC-227ea is exposed to temperatures greater than 1300° F (700° C), the by-product Hydrogen Fluoride (HF) will be formed. HFC-227ea systems are designed to discharge in 10 seconds or less in order to minimize the amount of HF formed.

The HFC-227ea Material Safety Data Sheet (MSDS) should be read and understood prior to working with the agent.

A cylinder containing HFC-227ea should be handled carefully. **The anti-recoil safety device must be in place at all times when the cylinder is not connected to the discharge piping and restrained.**

Time for Safe Human Exposure at Stated Concentrations for HFC-227ea		
HFC-227ea Concentration		Maximum Human Exposure Time (Minutes)
% v/v	ppm	
9.0	90,000	5.00
9.5	95,000	5.00
10.0	100,000	5.00
10.5	105,000	5.00
11.0	110,000	1.13
11.5	115,000	0.60
12.0	120,000	0.49

Notes:

1. Data derived from the EPA-approved and peer-reviewed PBPK model or its equivalent.
2. Based on LOAEL of 10.5% in dogs.